

Produktbild
Product picture



 **BP0-Profil 3610**

BP0-profile 3610

Artikelnummer: 105007007

*Verbindung zwischen Trapezdach/Flachdach & Modulklemme
- individuell kürzbar*

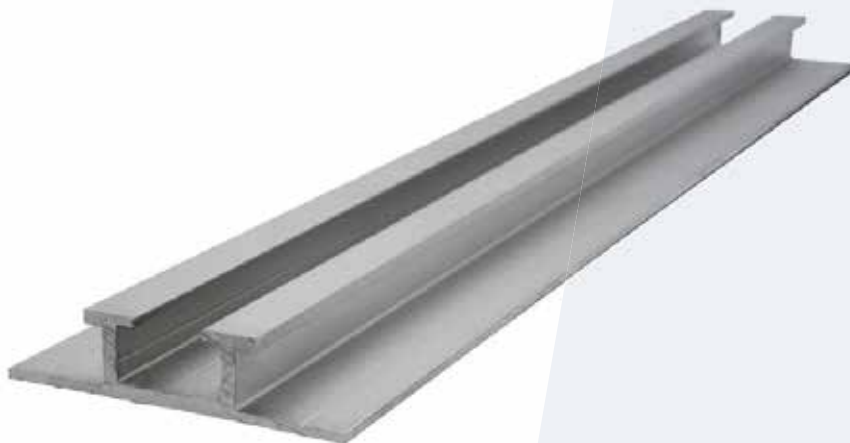

System assembly system

Wave

Komponententyp type of component

Sockelprofil base profile

Materialien materials

Aluminium aluminum

Gewicht Einzelteil unit weight

2502 [g]

 **BP0-Profil 3610**

BP0-profile 3610

Artikelnummer: 105007007

*Verbindung zwischen Trapezdach/Flachdach & Modulklemme
- individuell kürzbar*

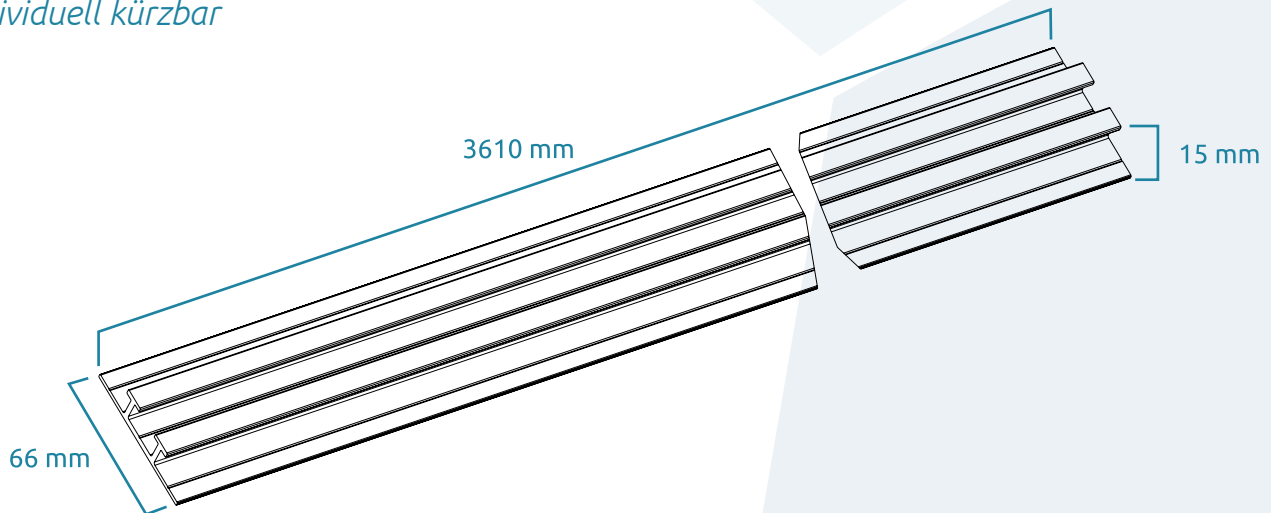

System	assembly system	Wave	
Komponententyp	type of component	Sockelprofil	base profile
Materialien	materials	Aluminium	aluminum
Gewicht Einzelteil	unit weight	2502	[g]
<i>Weitere Informationen</i>			
Karton/Box-Maße	box dimensions	33,5 x 27 x 11,5	[cm]
Gebindegröße	units per box	228	[stk]
Gewicht je Karton (brutto)	weight per box (gross)	579,5	[kg]
Kartons/Boxen je Palette	boxes per pallet	1	[stk]
Paletten-Maße	pallet size	360x42x45	[cm]
Gewicht je Palette (brutto)	weight per pallet (gross)	579	[kg]